

List fall hazards on site

Explain dangers

Falls are the number one cause of serious injuries and death from injuries in construction.

Identify controls

Guardrails are often the best and most convenient means of fall protection.

Where possible, guardrails must be installed

- along the open edges of roofs and floors
- on formwork, scaffolds, and other work surfaces
- openings in floors and roofs
- wherever workers are exposed to the risk of falling.

Guardrails must be installed no more than 30 cm (1 foot) from the open edge. They must be able to withstand all loads specified in the construction regulation (Ontario Regulation 213/91).

Posts supporting a wooden guardrail should be no more than 8 feet apart. Guardrails can also be wire rope and manufactured systems of metal frames and wire mesh.

Well-anchored posts are essential. You can use vertical shoring jacks, screw-clamp posts, clamp binding posts, or posts that fit into sleeves cast right in the slab.

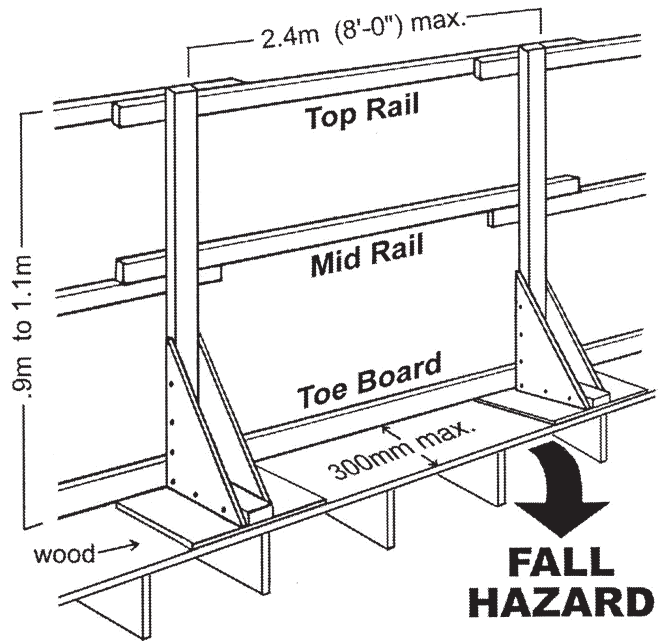

Sometimes guardrails have to be removed to land material or make installations along floor or roof edges. The open edge should be roped off and marked with warning signs. Workers inside that area must wear fall protection and be tied off.

All guardrails—especially wood guardrails—should be inspected regularly.

Guardrails are the best method of protecting workers around openings in floors and roofs, but sometimes they're not practical. You may have to use securely fastened covers made of planks, plywood, or steel plate. Covers must be strong enough to support any weight to be reasonably expected.

There's always the danger that someone will pick up the plywood to use somewhere else. Workers have even removed covers from openings and then fallen through.

That's why covers should be clearly marked in bright paint with warning signs. **DO NOT REMOVE. DANGER! HOLE IN FLOOR.**

Demonstrate

Review types of guardrails used on site. Ask your crew where else guardrails should be installed.